

Dimensional drawing

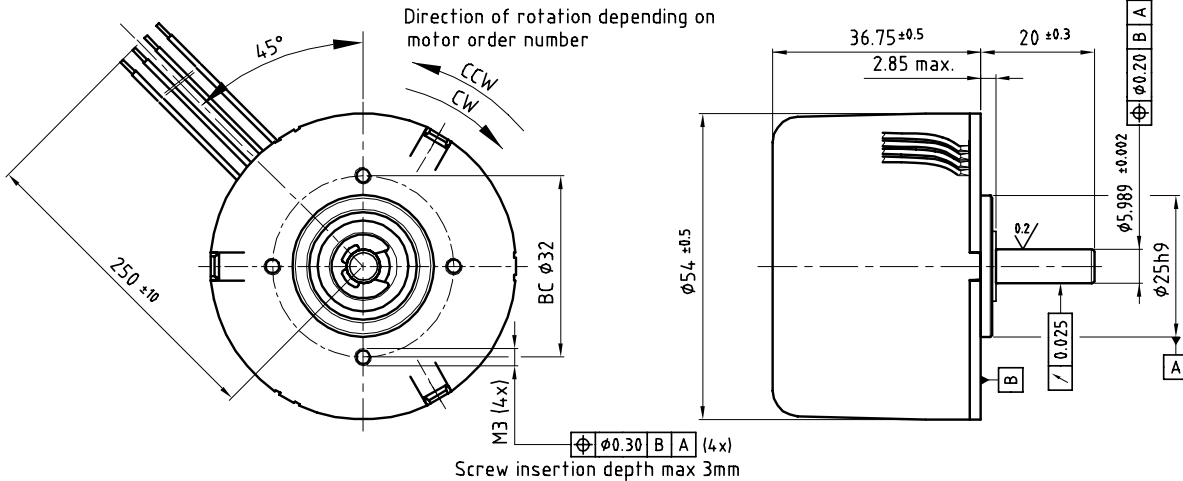

Motor data

Motor order number	CW	4322 016 +	48027	48037
	CCW	4322 016 +	48023	48033
Nominal voltage	[V]	12	24	
Voltage range	[V]	10 .. 15	14 .. 28	
Max. output power	¹⁾ [W]	12	12	
No load speed	²⁾ [rpm]	4600	4600	
No load current	²⁾ [mA]	230	140	
Min. starting torque	²⁾ [mNm]	53	57	
Nominal torque	²⁾ [mNm]	30	30	
Nominal speed	²⁾ [rpm]	3200	3200	
Nominal current	²⁾ [A]	1.28	0.66	
Max. current limit	[A]	2.13	1.04	
Max. continuous torque	¹⁾ [mNm]	43	43	
Min. adjustable speed	[rpm]	200	200	
Rotor inertia	[kgm ²]	31x10 ⁻⁶	31x10 ⁻⁶	
Mechanical time constant	[ms]	51	41	
Max. flange temperature	¹⁾ [°C]	85	85	

All relevant values in above table are valid for nominal supply voltages and Tamb.=22°C

- ¹⁾ For thermal reasons it is advised to mount the motor on a heat conducting frame if high output power is desired.
- ²⁾ At Vctrl=5.0V

Maximum radial load 15 mm from mounting front at 3000 rpm	[N]	40
Mass of motor	[g]	250

Performance curves

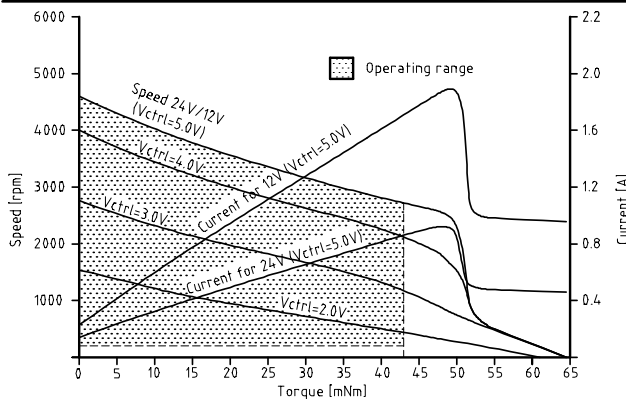

PREMOTEK

PRECISION MOTOR TECHNOLOGY BV
Precision Motor Technology b.v. - Kerkeplaat 16 - 3313 LC - Dordrecht -

Electrical Connection

Lead colour	Signal name	Function	Size
red	+Vs	+Supply voltage	AWG 24
blue	GND	Ground (0V)	AWG 24
white	Vctrl	Control voltage input	AWG 24
green	FG	Frequency Generator output	AWG 24

Reversed connection of +V and Ground wires can lead to motor damage

Vctrl input data		
Control voltage range	[V]	0---5
Max. input voltage	[V]	±30
Threshold voltage	[V]	1.0±0.2
Speed/Vctrl relation (at no load)	[rpm/V]	typ. 1250
FG output data		
FG pulses per revolution		6
Pulse length 'high'	[ms]	typ. 1.7
Output series resistance	[Ohm]	3k9
Output level 'high' (Iout<0.1mA)	[V]	4.2---5.4
Output level 'low' (Iout<0.1mA)	[V]	<0.5

Product combinations

- * Gearbox P42A
- * Gearbox S64A
- * Gearbox S69A

Options

- * Special shafts, diameter 3...6 mm
- * Direction of rotation pre-set (internal)
- * Square foot mounting flange

Features

- * 4-wire concept with an extra lead for Frequency Generator output and a lead for speed adjustment (PWM control of motor voltage)
- * Long life (up to 20.000 hours)
- * EMC compliance with standards EN 55011, EN 55022 and EN 50082-1 ³⁾
- * Input and output signals protected against wrong connection
- * Protection class IP30

³⁾ Capacitor of 1000 µF (for 12 V motor) or 470 µF (for 24 V motor) needed at the outlet of the power supply.