

BL21 EE

Brushless DC motor

Dimensional drawing

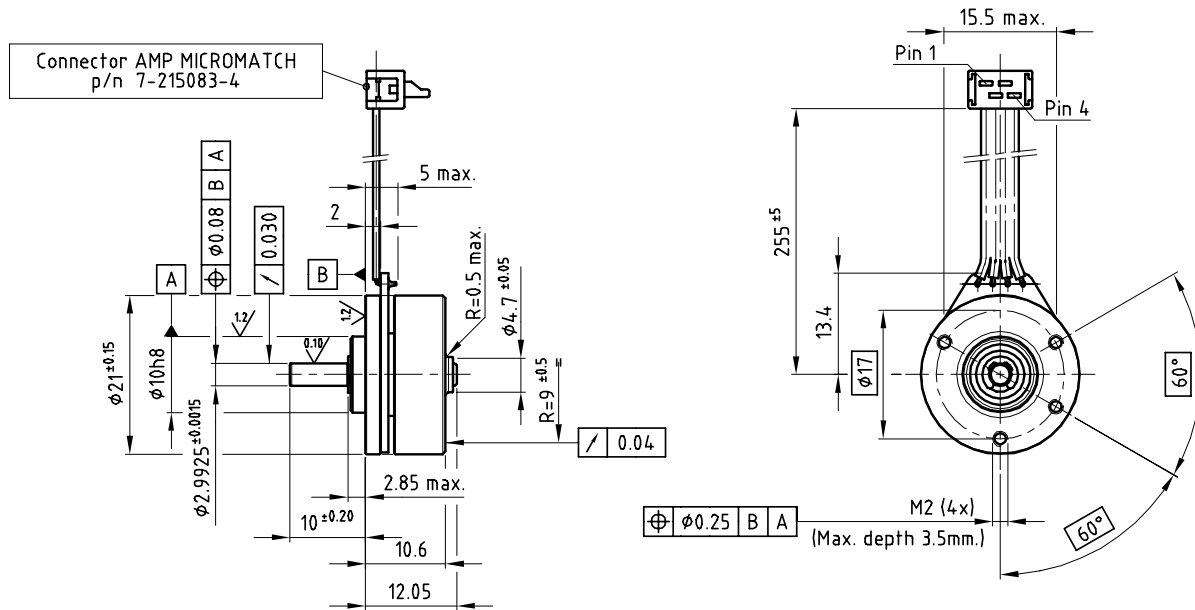

Motor data

Motor order number	4322 016 21011	
Nominal Voltage	[V]	12
No load Speed	[rpm]	5600
Torque constant	[mNm/A]	17
Stator resistance between two phases	[Ohm]	39
Stator inductance between two phases	[mH]	5
Mechanical time constant	[ms]	75
Max. winding temperature	[°C]	90
Thermal resistance from winding to ambient	[K/W]	62
Thermal resistance from winding to ambient with cooling plate (aluminium, 100x100x2)	[K/W]	32
Operating temperature range	[°C]	0 / +50
Insulation resistance at 500 V	[M Ohm]	min. 1
Rotor inertia	[kgm ²]	0.53x10 ⁻⁶
Mass of motor	[g]	16

Maximum radial load 8 mm from mounting front at 6000 rpm (no axial load towards flange)	[N]	3.0
Maximum axial load at 6000 rpm - towards flange (no radial load) - from flange	[N]	2.0
	[N]	1.0

Brushless DC motor with laminated 9 coil stator and 12 pole rotor, fitted with 4 wire flat cable and connector.
Motor using sensorless drive technology, to be used in combination with back-EMF commutating motor-IC (like Philips TDA 51... family).
Coil configuration: 3 phases, Y connected.

For thermal reasons it is advised to mount the motor on a heat conducting frame if high output power is desired.

Electrical Connection

Pin no.	Description
1	Centre tap
2,3,4	Phase leads

Options

- * Gearboxes

Performance curve

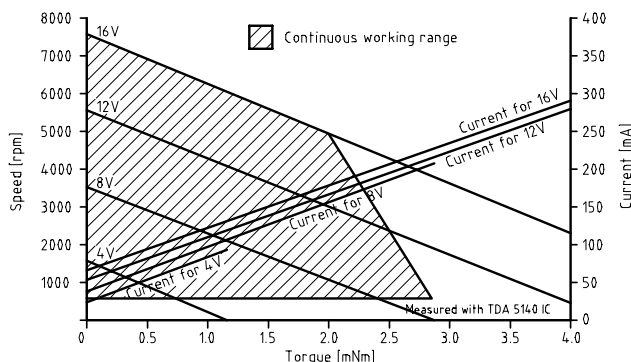

Features

- * Compact, low mounting profile
- * Low acoustical noise
- * Long life (20.000 hours)
- * Low EMI

color-technik
Antriebstechnik GmbH
Starkenburgerstr. 6 * 64546 Mörfelden
Tel.:06105 24044 * Fax:06105 25593
info@color-technik.net
www.color-technik.net

PREMOTEC

PRECISION MOTOR TECHNOLOGY BV

Precision Motor Technology b.v. - Kerkeplaat 16 - 3313 LC - Dordrecht - The Netherlands - Tel.: +31 78 621 99 40 - Fax.: +31 78 621 48 28

1999-11-17 / subject to change

Internet : www.premotec.com - E-mail : sales@premotec.com